

**Significant
energy savings**

**Safe and
reliable
control**

**Flexible
installation**

A large circular graphic with a green-to-yellow gradient background and a silver metallic border. The text "Frese" is at the top, "FUELSAVE®" is in the middle in a bold white font, and "Optimise to Economise" is at the bottom in a smaller white font.

Frese
FUELSAVE®
Optimise to Economise



Marine Cooling Water Systems

Energy-efficient Flow Management

Call for Action to Fight Climate Change

Call for action to fight climate change on the back of the Paris Agreement is ramping up and the global maritime shipping industry has stepped up to the challenge in terms of pledging to reduce its annual CO2 emissions of nearly 1.000 million tonnes by at least 40% by 2030 and 70% by 2050.

Latest carbon intensity and energy efficiency measures outlined by the International Maritime Organization (IMO) agreed back in July 2021, effective start of 2023, are designed to deliver these emission reduction targets.

Recent years have witnessed a significant cost increase in traditional fuels and the new electrofuels being introduced will be very costly for the foreseeable future.

The demands for efficiency have never been greater on those who own, operate and build commercial marine vessels. You are tasked with reducing costs while maintaining performance, crew safety and compliance with environmental regulations.

To help you address these challenges Frese has redefined what is possible in terms of achievable energy savings in your vessels' cooling water systems – which means fuel savings and less CO2 emitted.

We call this patent pending solution the **Frese FUELSAVE® System** – with a return of investment under two years.



More than the Sum of the Parts

The Mechanical Concept

Frese FUELSAVE realises the unique fuel savings opportunities that are embedded in Frese's well-proven automatic balancing and control valve technology.

Frese automatic balancing and control valves are designed to keep a constant flow rate irrespective of the pump pressure supplied when exposed to a pressure higher than the minimum pressure required by the valve.

In a cooling water system, one valve or cooling consumer will always be hydraulically the most far away from the pump and thus dictate the pump pressure required. We call it the index valve.

In Frese FUELSAVE we identify the index valve and adjust the pump speed to give minimum differential pressure. Thereby all other cooling consumers are operating at the system pressure and thus guaranteed to provide the specified flow rate.

In this way, the cooling water needed for safe operation is safeguarded, while at the same time pump energy consumption is reduced to an absolute minimum, guaranteeing that no overflows occur.

At the individual cooling consumers, the cooling water amount will be controlled and reduced with local process parameters, such as equipment running signal, temperature or pressure sensors, depending on the specific project.

The Frese FUELSAVE system will, apart from the fresh water cooling temperature and pressure control, also include use of market leading energy-efficient 3-way temperature valves and optimisation of sea water pumps.

The Control System

The control system collects all the sensor data and uses it to ensure continuous optimum pump operation at any given load condition.

By combining decentralised controllers and sensors for safety and reliability with a central interface for the operation system, you get a system without compromises.

A full package includes the delivery and commissioning of all electrical equipment and of the entire system.

How can Frese FUELSAVE® Save Energy Onboard?

The key to reduce pump energy is to reduce the flow rates at the individual cooling consumers. The potential savings are illustrated in the graph.

Example:

A flow reduction of **50%** will reduce the pump energy to between **50** and **12.5%**

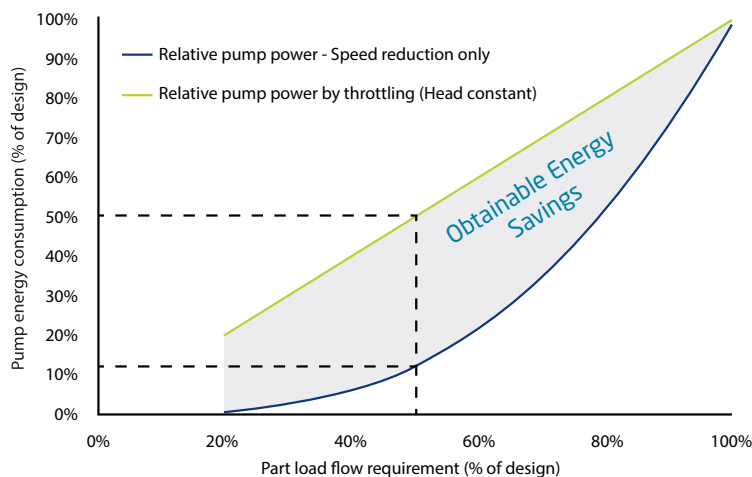

Typical Impact of Frese FUELSAVE® on Various Ship Types

The result of detailed simulations of cooling water systems onboard various ship types can be seen in the table.

Vessel type	Existing installations			Vessel operation					Frese FUELSAVE		Fuel reduction
	M/E/MCR (kW)	SW Pump - Design (kW)	LTFW - Design (kW)	Annual CO2 emission (tonnes)	Capacity	Distance sailed (n. miles)	CII reference line value	CII attained	LTFW pump fuel saving (MT/year)	SW pump Fuel saving (MT/year)	CII attained reduction %
Bulk Carrier - Handysize	7,050	45	62	3,972	27,000	18,153	8.3	8.1	65	55	9%
Tanker - MR2	9,480	74	90	9,056	60,000	24,094	6.4	6.3	94	91	6%
Containership - 3000 TEU Class	25,270	113	130	24,546	43,127	49,575	10.7	11.5	137	139	3.5%
Containership - 10000 TEU Class	60,200	200	202	30,180	115,800	36,507	6.6	7.1	212	245	5%
LNG carrier (< 100,000 DWT)	25,040	133	133	26,433	80,000	38,872	11.3	8.5	139	163	4%
Ro-Ro passenger ship	24,000	92	91	23,839	13,000	67,817	26.2	27.0	96	113	3%

BENEFITS

By introducing the Frese FUELSAVE concept in planned new builds or as part of a retrofit, you will achieve benefits on several levels:

System Benefits	<ul style="list-style-type: none">+ Simplified system design+ Overflows eliminated+ Fewer components	<ul style="list-style-type: none">+ Cooling water system always in balance+ Optimum energy savings+ Simplified commissioning of system
Financial Benefits	<ul style="list-style-type: none">+ Consist of well-proven and developed equipment technology, providing cost-effective equipment package	<ul style="list-style-type: none">+ Payback time less than 2 years and ongoing reduction of OPEX during the lifetime of the vessel
Environmental Benefits	<ul style="list-style-type: none">+ Large amounts of otherwise unrevealed fuel savings result in vast amount of emission reductions. Carbon Intensity index of entire vessel can be reduced with 3-9%	



Frese FUELSAVE®

Optimise to Economise

This superior flow management system uses well-proven differential pressure control and balancing, providing the most simple and energy-efficient cooling water system in the market.

Maximise your CO₂ reductions and get considerable fuel savings without compromising the safety and reliability of your vessel.

1

The flow is distributed by pressure independent control and balancing valves positioned at each client. Flow is reduced at any given load based on individual control signals.

2

Optimum pump savings are obtained by running the pump via signal from external differential pressure transmitter (DPT) positioned at critical points in the system.

3

Overall temperature is controlled by low pressure drop and zero leakage 3-way valve.

Simplified Mechanical System P&ID

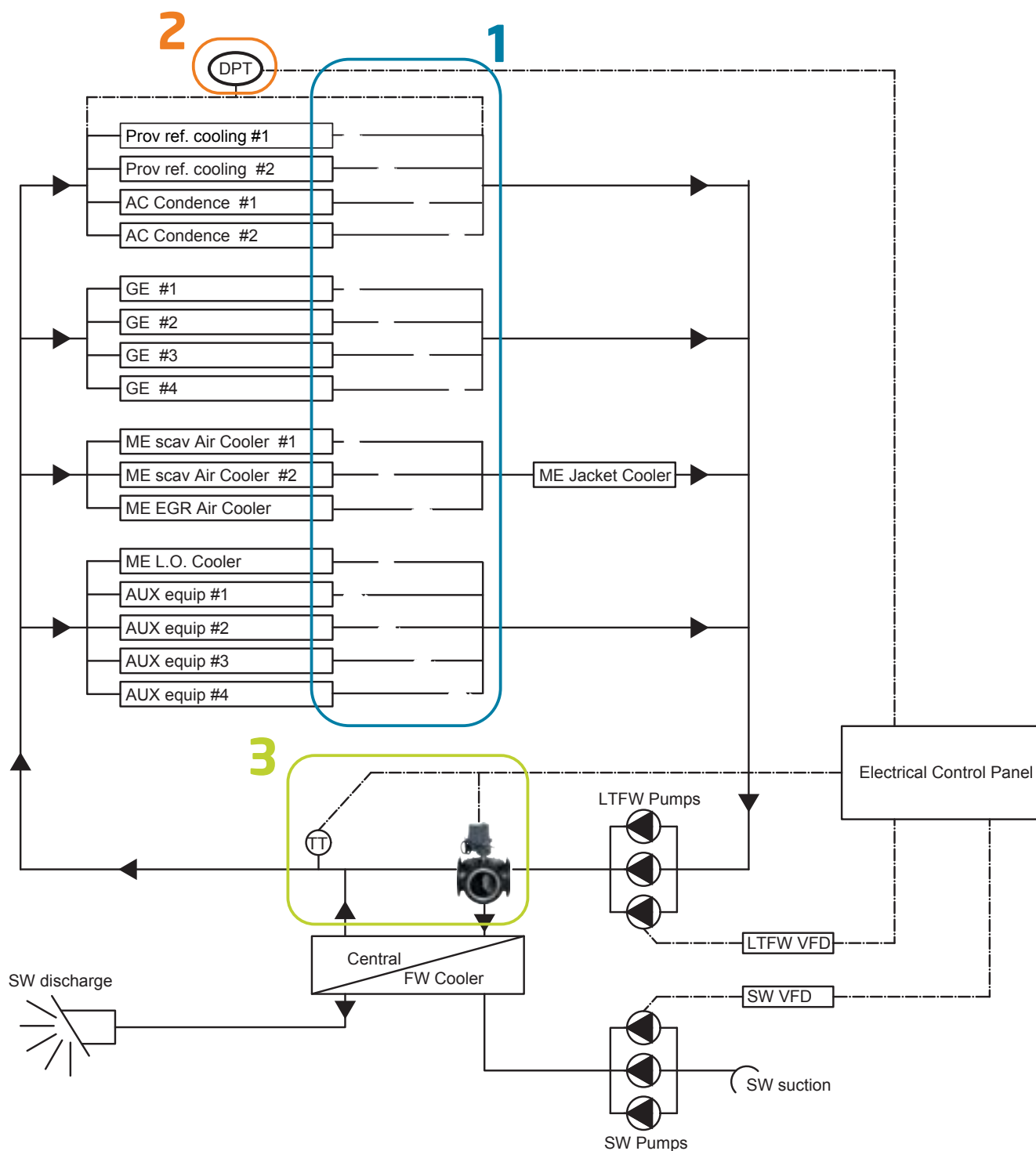

FUELSAVE® System Modules

Control System & Electrical Overview

Automation

The heart of the Frese FUELSAVE® system undertakes all the necessary control and monitoring to optimise the complete cooling water system.

VFDs

The variable frequency drives (VFDs) regulate pump speed according to required flow.

2-way valves

Frese's patented pressure independent valve technology ensures that the fresh water cooling system is always in balance and that the cooling water distribution is minimised to enable optimum pump speed reduction.

3-way valves

Overall temperature is controlled by low pressure drop and zero leakage 3-way valve.

Switch Board Room

Engine Room

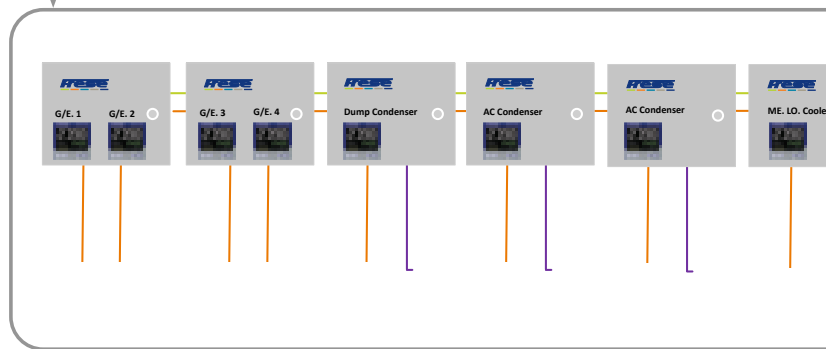
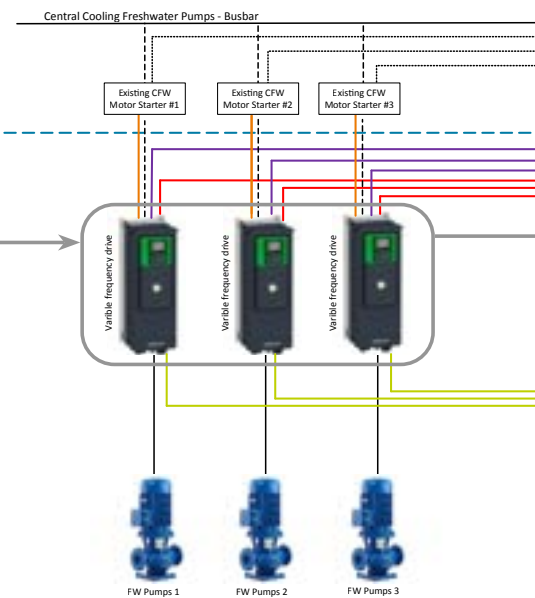

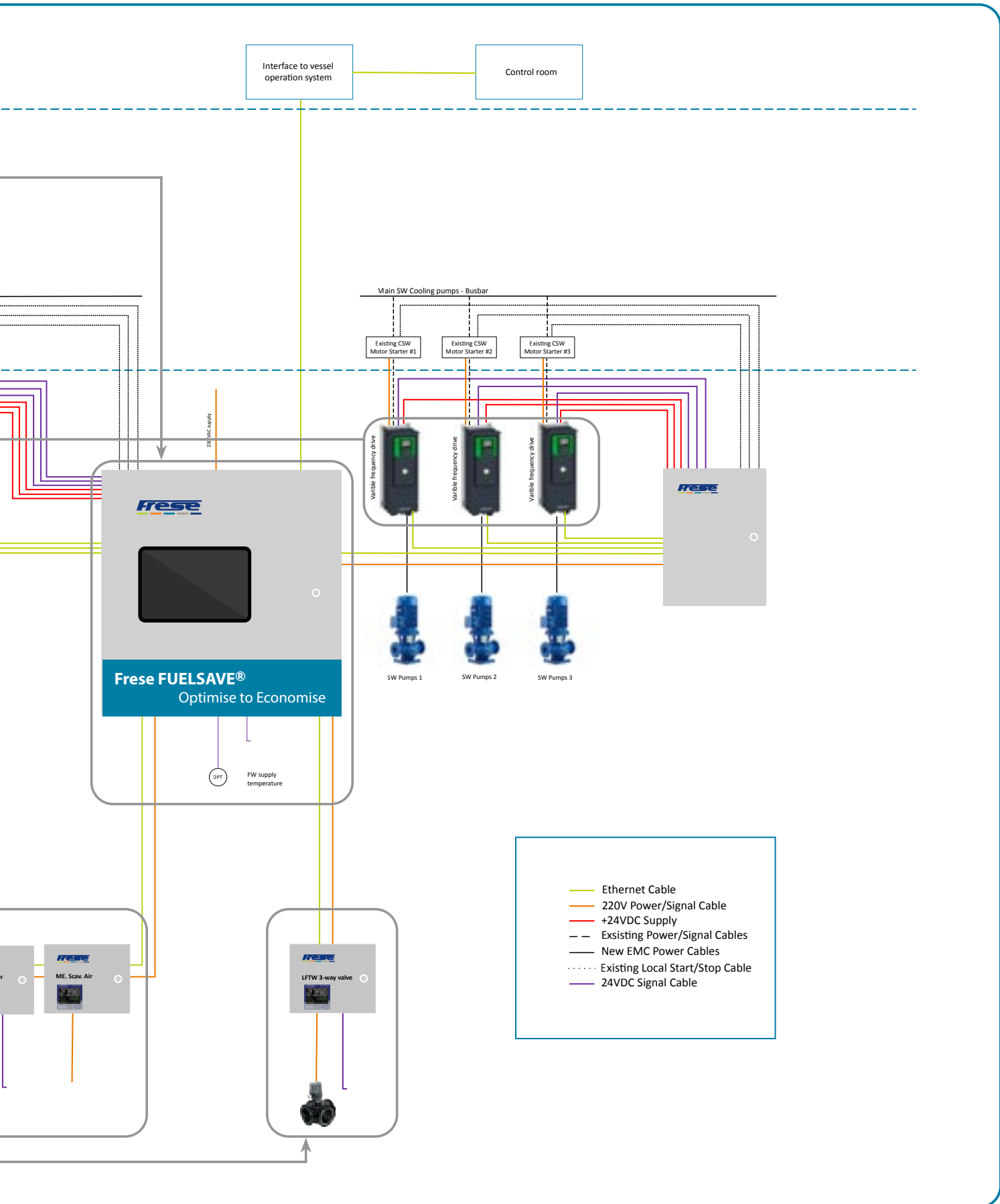

Choose One or More Modules at a Pace That Suits You

	Automation module	2-way valve module
Module	The heart of the Frese FUELSAVE system undertakes all the necessary control and monitoring to optimise the complete cooling water system.	Frese patented pressure independent valve technology ensuring that the fresh water cooling system is always in balance and that the cooling water distribution is minimised to enable pump speed reduction.
What's included	<p>FUELSAVE cabinet with monitor enables:</p> <ul style="list-style-type: none"> + Control of LT pumps* based on differential pressure (DPT Sensor included) + Control of LT 3-way valve based on temperature + Simplified commissioning of system + Control of SW pumps* (temp. sensor included) + Prepared for remote access and cloud-based monitoring of system performance + dP-Switch ensuring minimum pump speed can be achieved <p><i>* Max 3 pumps in each system</i></p>	<ul style="list-style-type: none"> + Pressure Independent Control Valves with local controllers based on <ul style="list-style-type: none"> - Temperature - dT - P - On/off control + Automatic balancing valves for small cooling customers
Options	1 2 3 4 6 7 8	3 (depending on option 1) 5 6 8
Features	<ul style="list-style-type: none"> + Fast Device Replacement (FDR), if a VFD fails and is replaced in port, then the PLC will feed the replacement the same parameters + Update of the web application and the PLC control can be done using SD cards + Text message notification is embedded in the PLC + One panel controlling entire cooling water system + 230V power supply to all actuators enables flexible cable configurations + Remote support + All components are mounted in one cabinet for easy access and protection + The panel can be upgraded for future needs, so there is no need for scrapping existing hardware 	<ul style="list-style-type: none"> + Can be integrated in automation module or work as standalone + Actuators are failsafe to open on both power supply and control signal failure + Automatic balancing eliminates overflows, regardless of fluctuating pressure conditions in the system + Total number of valves minimised due to the 3-in-1 design + Minimised commissioning time due to automatic balancing of the system + No minimum straight pipe lengths required before or after the valve + Longer life due to less movements of the actuator + Full stroke modulation at all times + Flow estimation in automation module giving clear overview of cooling water distribution at all times

Options

- 1 Integration of 2- and 3-way valves in main Frese FUELSAVE Control Panel
- 2 LTFW Booster pump control incl. VFD and dPT-sensor
- 3 Performance monitoring via cloud
- 4 Control of existing VFDs (analogue)
- 5 3D-scan + prefabricated pipes
- 6 Electrical installation and supervision
- 7 Electrical engineering for special applications
- 8 Mechanical installation and supervision

Services included

- + Mapping of flow distribution and critical consumers based on existing heat balance
- + Definition of control concept for cooling consumers
- + Energy savings calculations
- + Specification for detailed engineering and implementation
- + Commissioning



3-way valve module	Variable frequency drive module
<p>Frese OMEGA Compact low leakage low pressure drop rotary 3-way valve controlling main supply temperature in fresh water cooling system.</p>	<p>Variable frequency drives (VFDs) regulate pump speed according to required flow.</p>
<ul style="list-style-type: none"> + Rotary 3-way valve + Actuator + PID controller in wall-mounted cabinet + Temperature sensor 	<ul style="list-style-type: none"> + Available in all sizes and ratings necessary for the existing pumps in the installation + Protective measures included: <ul style="list-style-type: none"> - Driverun protection - LowFlow protection - HighFlow protectio - Pump cavitation protection
<p>3 (depending on option 1) 5 6 8</p>	<p>2 3 (not possible with option 4) 6 8</p>
<ul style="list-style-type: none"> + Can be integrated in automation module or work as standalone + The valves have failsafe open for pneumatic actuators and failsafe in-place for electric actuators + Possibility of monitoring energy consumption on individual consumers if temperature sensors are added + Market leading high kV value and near zero leakage rate providing additional energy savings + When connected to the automation module, an optimum control of SW pump speed and FW 3-way valve with no offset in temperature is provided 	<ul style="list-style-type: none"> + The configuration can be sent via e-mail and transferred to the VFD behind the HMI through a mini-usb (laptop) + They have a standby function with a maximum power consumption of 20w + Flow Estimation can be done with an 5% accuracy + It will therefore be possible to make KPIs on various desired parameters, e.g., kW/m3 + They have 3-phased kW/h-meter + They have 3C3 coating without any extra cost + Fast replacement is possible with a minimum amount of VFDs on stock. By having the largest VFD on stock, all smaller versions can be replaced by this if needed creating an immediate failsafe + VFDs assist the flow optimisation in the system

Frese FUELSAVE®

More than the Sum of the Parts



www.frese.eu/marine

 marine@frese.dk

 +45 58 56 00 00